

DEVILBISS
AUTOMOTIVE REFINISHING

DV1 CLEARCOAT Gravity Spray Gun

CE  II 2 G X

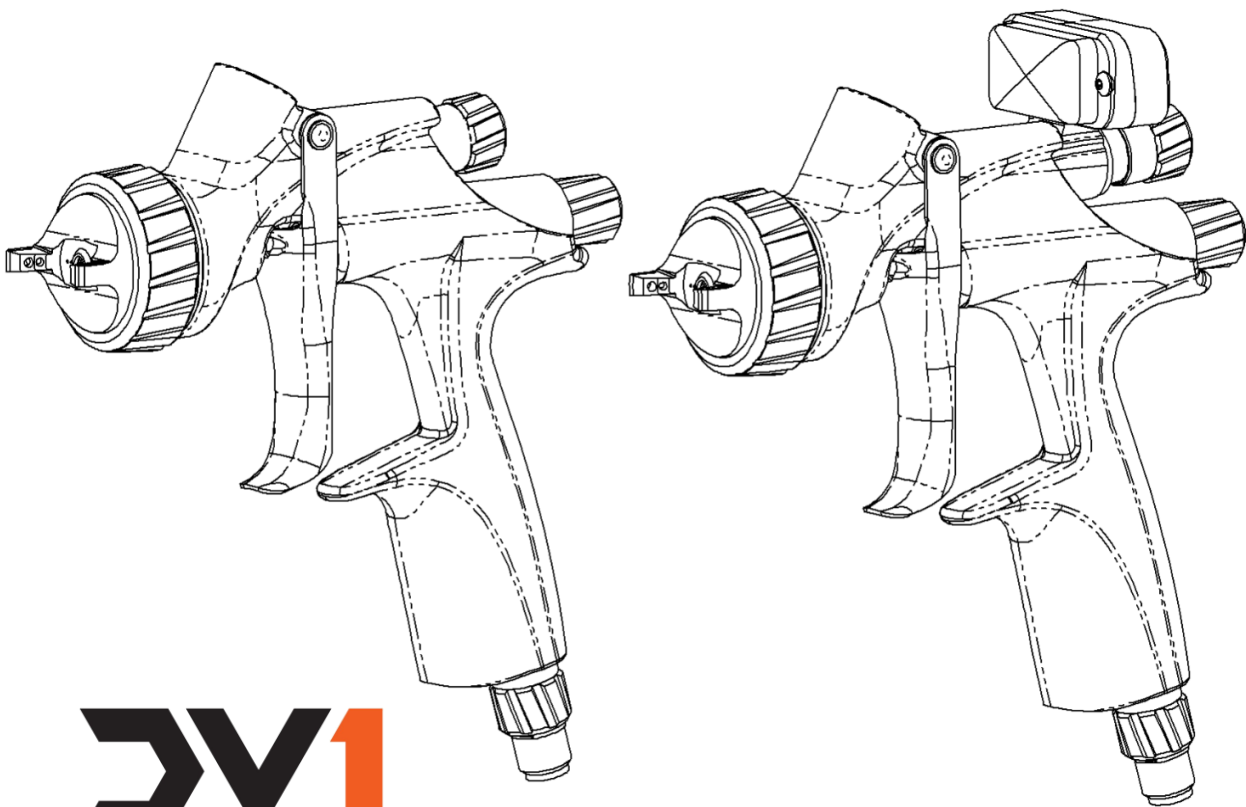

DV1
CLEARCOAT

IMPORTANT! DO NOT DESTROY

It is the Customer's responsibility to have all operators and service personnel read and understand this manual.

Contact your local Carlisle Fluid Technologies representative for additional copies of this manual.

READ ALL INSTRUCTIONS BEFORE OPERATING THIS PRODUCT.

FUNCTIONAL DESCRIPTION

The DV1 spray gun is a professional quality spray gun designed to comply with all global legislations.

SPECIFICATIONS

AIR INLET PRESSURES	
P1 = Max. Static Air Input Pressure	12 bar [175 psi]
Gun Air Inlet Pressure with gun triggered	See Table 1 Page 8
Vibration Level:	<2.5 m/s ²
Sound Power Level:	Available On Request
Sound Pressure Level:	Available On Request

ENVIRONMENTAL	
Max. Ambient Operating Temperature	40°C Nominal [104°F]

MATERIALS OF CONSTRUCTION	
Gun Body Material	Anodised Aluminium
Fluid Tip, Fluid Needle and Trigger Stud	Stainless Steel
Air Cap Material	Electroless Nickel Plated Brass
Retaining Ring, Sprayhead, Adjusting Knobs, Air Valve Cage, Sleeve	Anodised Aluminium
Springs, Clips, Screws	Stainless Steel
Seals and O-Rings	Solvent Resistant
Trigger	Chrome Plated Steel
Valve Bodies, Rear Housing, Packing Nut, Sleeve Nut	Chrome Plated Brass
Air Valve Stem	Electroless Nickel Plated Brass

CONNECTIONS	
P1 = Air Inlet Size	1/4" Universal
P2 = Fluid Inlet Size	3/8" BSP

WEIGHT	
GUN ONLY	470g [16.6 oz]

DIMENSIONS	
L x H x W mm [inches]	161 x 177 x 44 [6.3 x 7.0 x 1.7 in]

Product Description / Object of Declaration: DV1

This Product is designed for use with: Solvent and water based materials

Suitable for use in hazardous area: Zone 1 / Zone 2

Protection Level: II 2 G X/Ex h II Gb X

Notified body details and role: Element Materials Technology (0891)
Lodging of Technical file

This Declaration of conformity / incorporation is issued under the sole responsibility of the manufacturer: Carlisle Fluid Technologies UK Ltd,
Ringwood Road,
Bournemouth, BH11 9LH. UK

EU Declaration of Conformity



The object of the declaration described above is in conformity with the relevant Union harmonisation legislation:

ATEX Directive 2014/34/EU

Machinery Directive 2006/42/EC

by complying with the following statutory documents and harmonised standards:

EN 1127-1:2011 Explosive atmospheres - Explosion prevention - Basic concepts

BS EN 1953:2013 Atomising and spraying equipment for coating materials - Safety requirements

EN ISO 12100:2010 Safety of Machinery - General Principles for Design

EN ISO 80079-36:2016 Explosive Atmospheres- Part 36:Non Electrical equipment for explosive atmospheres- Basic methods and requirements.

EN ISO 80079-37:2016 Explosive Atmospheres- Part 37: Non Electrical equipment for explosive atmospheres - protection by methods "c", "b" and "k".

Providing all conditions of safe use / installation stated within the product manuals have been complied with and also installed in accordance with any applicable local codes of practice.

Signed for and on behalf of Carlisle Fluid
Technologies UK Ltd:

A handwritten signature in black ink, appearing to read 'D Smith'.

D Smith
1/8/18

Director of Sales (EMEA)

In this part sheet, the words WARNING, CAUTION and NOTE are used to emphasise important safety information as follows:

EN

 WARNING	 CAUTION	NOTE
Hazards or unsafe practices which could result in severe personal injury, death or substantial property damage.	Hazards or unsafe practices which could result in minor personal injury, product or property damage.	Important installation, operation or maintenance information.

 **WARNING**

Read the following warnings before using this equipment.



SOLVENTS AND COATING MATERIALS. Can be highly flammable or combustible when sprayed. Always refer to the coating material supplier's instructions and safety sheets before using this equipment.



INSPECT THE EQUIPMENT DAILY. Inspect the equipment for worn or broken parts on a daily basis. Do not operate the equipment if you are uncertain about its condition.



READ THE MANUAL. Before operating finishing equipment, read and understand all safety, operation and maintenance information provided in the operation manual. Users must comply with all local and national codes of practice and insurance company requirements governing ventilation, fire precautions, operation and house-keeping of working areas.



EQUIPMENT MISUSE HAZARD. Equipment misuse can cause the equipment to rupture, malfunction or start unexpectedly and result in serious injury.



FIRE AND EXPLOSION HAZARD. Never use 1,1,1-Trichloroethane, Methylene Chloride, other Halogenated Hydrocarbon solvents or fluids containing such solvents in equipment with aluminium wetted parts. Such use could result in a serious chemical reaction, with the possibility of explosion. Consult your fluid suppliers to ensure that the fluids being used are compatible with aluminium parts.



GLOVES. Must be worn when spraying or cleaning the equipment.



WEAR SAFETY GLASSES. Failure to wear safety glasses with side shields could result in serious eye injury or blindness.



STATIC CHARGE. Fluid may develop a static charge that must be dissipated through proper grounding of the equipment, objects to be sprayed and all other electrically conductive objects in the dispensing area. Improper grounding or sparks can cause a hazardous condition and result in fire, explosion or electric shock and other serious injury.



WEAR RESPIRATOR. The use of respiratory protective equipment is recommended at all times. The type of equipment must be compatible with the material being sprayed.



TOXIC VAPOURS. When sprayed, certain materials may be poisonous, create irritation, or are otherwise harmful to health. Always read all labels, safety sheets and follow any recommendations for the material before spraying. If in doubt contact your material supplier.



NEVER MODIFY THE EQUIPMENT. Do not modify the equipment unless the manufacturer provides written approval.



LOCK OUT / TAG-OUT. Failure to de-energise, disconnect, lock out and tag-out all power sources before performing equipment maintenance could cause serious injury or death.

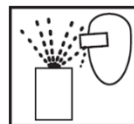

PROJECTILE HAZARD. You may be injured by venting liquids or gases that are released under pressure, or flying debris.



NOISE LEVELS. The A-weighted sound level of pumping and spray equipment may exceed 85 dB(A) depending on equipment settings. Actual noise levels are available on request. It is recommended that ear protection is worn at all times while equipment is in use.



PRESSURE RELIEF PROCEDURE. Always follow the pressure relief procedure in the equipment instruction manual.



KNOW WHERE AND HOW TO SHUT OFF THE EQUIPMENT IN CASE OF AN EMERGENCY.



HIGH PRESSURE CONSIDERATION. High pressure can cause serious injury. Relieve all pressure before servicing. Spray from the gun, hose leaks or ruptured components can inject fluid into your body and cause extremely serious injury.



OPERATOR TRAINING. All personnel must be trained before operating finishing equipment.

IT IS THE RESPONSIBILITY OF THE EMPLOYER TO PROVIDE THIS INFORMATION TO THE OPERATOR OF THE EQUIPMENT.

EXPLODED VIEW

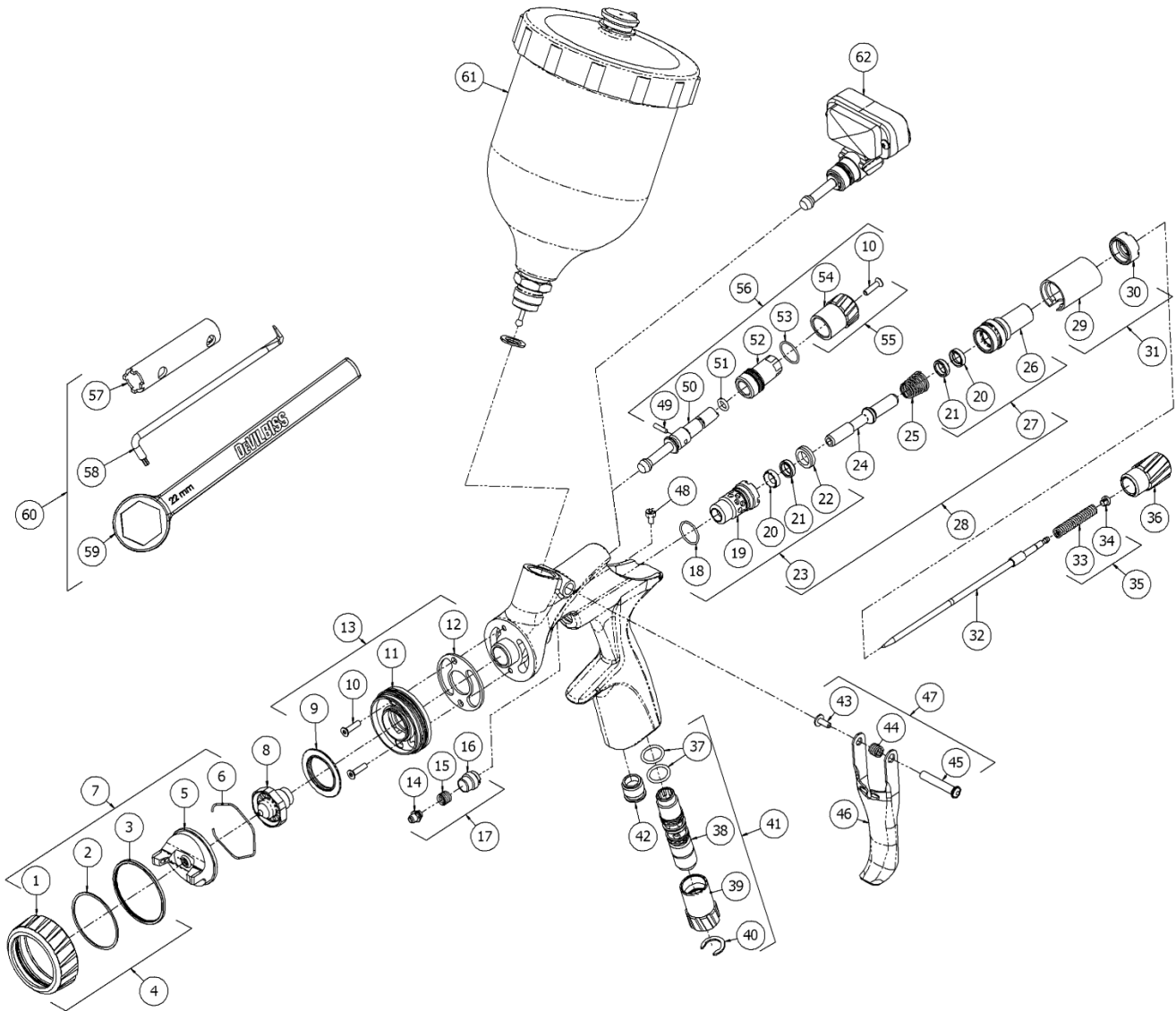

PARTS LIST

REF.	PART No.	DESCRIPTION	QTY.
1	-	RETAINING RING	1
2	-	SLIP RING	1
3	-	RETAINING RING SEAL	1
4	704425	RETAINING RING SUB ASSEMBLY	1
5	-	AIR CAP	1
6	191972	SPRING CLIP (KIT OF 10)	1
7	SEE TABLE 1	AIR CAP & RETAINING RING	1
8	SEE TABLE 3	FLUID TIP	1

PARTS LIST (Continued)

REF.	PART No.	DESCRIPTION	QTY.
9	704402	DEFLECTOR PLATE	1
10 +	704403	SCREW (KIT OF 3)	3
11	-	SPRAYHEAD	1
12 +	704401	GASKET (KIT OF 2)	1
13	704436	SPRAY HEAD KIT	1
14	-	NEEDLE PACKING	1
15	-	PACKING SPRING	1
16	-	PACKING NUT	1
17 +	702731	PACKING, SPRING & PACKING NUT KIT	1
18	-	O RING	1
19	-	AIR VALVE CAGE	1
20	-	SEAL	2
21 *	-	SEAL GUIDE	2
22 *	-	VALVE SEAT	1
23 #	704422	FRONT CAGE ASSEMBLY	1
24	-	AIR VALVE STEM	1
25 #	-	AIR VALVE SPRING	1
26	-	REAR SEAL HOUSING	1
27	704423	REAR SEAL ASSEMBLY	1
28 +	704424	AIR VALVE ASSEMBLY	1
29	-	IDENTIFICATION SLEEVE	1
30	-	SLEEVE NUT	1
31	704437	SLEEVE KIT	1
32	SEE TABLE 3	FLUID NEEDLE	1
33	-	NEEDLE SPRING	1
34	-	SPRING PAD	1
35 #+	704405	NEEDLE SPRING KIT	1
36	704404	FLUID ADJUSTING KNOB	1
37	-	O RING	2
38	-	FLOW VALVE BODY	1
39	-	FLOW VALVE KNOB	1
40	-	CIRCLIP	1
41	704417	INLINE FLOW VALVE	1
42	-	PLUG	1
43	-	TRIGGER SCREW	1
44	-	SPRING	1
45	-	TRIGGER STUD	1
46	-	TRIGGER	1

PARTS LIST (Continued)

REF.	PART No.	DESCRIPTION	QTY.
47	704406	TRIGGER, STUD, SPRING & SCREW KIT	1
48	-	SCREW	1
49 #+	-	SPREADER VALVE PIN	1
50	-	SPREADER VALVE STEM	1
51 #+	-	O RING	1
52	-	VALVE BODY	1
53 #+	-	O RING	1
54	-	SPREADER VALVE ADJUSTING KNOB	1
55	704419	SPREADER KNOB KIT (Not For Use With Digital Gauge)	1
56	704418	SPREADER VALVE ASSEMBLY	1
57	-	VALVE TOOL	1
58	-	TORX DRIVER	1
59	-	TIP WRENCH	1
60	704429	TOOL KIT	1

* NOT REPLACEABLE

CUPS AND GAUGES

61	GFC-501	GRAVITY CUP PLASTIC	
	702576	GRAVITY CUP ALUMINIUM	
62	704426	ATEX APPROVED (EU)	DIGITAL PRESSURE GAUGE
	704427	FM APPROVED (USA, CANADA)	

SERVICE PARTS

704430	MINOR SERVICE KIT	INCLUDES ITEMS MARKED #
704431	MAJOR SERVICE KIT	INCLUDES ITEMS MARKED +

**WARNING**

The spray gun must be earthed to dissipate any electrostatic charges which may be created by fluid or air flows. This can be achieved through the spray gun mounting, or conductive air/fluid hoses. Electrical bond from the spray gun to earth should be checked and a resistance of less than 10^6 Ohms is required.

DV1

PART SELECTION GUIDE

TABLE 1

DV1 AIR CAP PERFORMANCE GUIDE

Part Number	Air Cap & Type		Recommended Air Inlet Pressure (with gun fully triggered)		Air Consumption	Typical Fan Pattern Size**
			At Gun Handle	At Digital Gauge		
704434	DV1-C1 PLUS	HVLP	2.0 bar [29 psi]	1.5 bar [22 psi]	285 L/min [10.0 scfm]	325 mm [12.8 in]
704435	DV1-C2 PLUS	HVLP	2.0 bar [29 psi]	1.5 bar [22 psi]	320 L/min [11.3 scfm]	310 mm [12.2 in]

** Fan pattern size @ 200mm [8"] distance.

TABLE 2

DV1 AIR CAP TEST KITS

Part Number	Air Cap & Type		Recommended Air Inlet Pressure (with gun fully triggered)		Atomisation Pressure
			At Gun Handle	At Digital Gauge	
704438	DV1-C1 PLUS	HVLP	2.0 bar [29 psi]	1.5 bar [22 psi]	0.689 bar [10 psi]
704439	DV1-C2 PLUS	HVLP	2.0 bar [29 psi]	1.5 bar [22 psi]	0.689 bar [10 psi]

TABLE 3

DV1 FLUID TIPS & NEEDLES

Fluid Tip			Needle	
Part Number	Fluid Tip Size	Marking	Part Number	Marking
704440	1.0	DV1-1.0 C	704416	DV1-300
704441	1.1	DV1-1.1 C		
704442	1.2	DV1-1.2 C		
704443	1.3	DV1-1.3 C		
704444	1.4	DV1-1.4 C		

**CAUTION**

IMPORTANT: This spraygun is suitable for use with both waterbased and solvent based coating materials.

- The gun is not designed for use with highly corrosive and/or abrasive materials.
- To avoid premature degradation of parts, DeVilbiss recommends the gun is washed in neutral cleaning solution (pH 6 to 8).
- The gun is not designed to be cleaned within an ultrasonic bath.

If there is any doubt regarding the suitability of a specific material, contact your DeVilbiss Distributor or DeVilbiss direct.

START-UP SEQUENCE

1. Connect the gun to a clean, moisture and oil free air supply using a conductive hose of at least 8mm I.D.
2. Mix coating material to Manufacturer's instructions and strain material.
3. Turn fluid adjusting knob (36) clockwise to prevent fluid needle movement.
4. Turn spreader valve adjusting knob (54) counter clockwise to fully open.
5. Adjust inlet air pressure if required.
6. Turn fluid adjusting knob counter clockwise until first thread shows.
7. Test spray. If the finish is too dry, reduce airflow by reducing air inlet pressure.
8. If finish is too wet, reduce fluid flow by turning fluid adjusting knob (36) clockwise. If atomisation is too coarse, increase air inlet pressure. If too fine, reduce inlet pressure.
9. The pattern size can be reduced by turning spreader valve knob (54) clockwise.
10. Hold gun perpendicular to surface being sprayed. Arcing or tilting may result in uneven coating.
11. The recommended spray distance is 150-200mm.[6-8"]
12. Spray edges first. Overlap each stroke a minimum of 75%. Move gun at a constant speed.
13. Always turn off air supply and relieve pressure when gun is not in use.

NOTE

Depending on hose length, larger I.D. hose may be required. Install an air gauge at the gun handle. When gun is triggered on, adjust regulated pressure as required. Do not use more pressure than is necessary to atomise the material being applied. Excess pressure will create additional overspray and reduce transfer efficiency.

NOTE

If quick connect couplings are required, use only high flow quick connects. Other types will not flow enough air for correct gun operation.

SPRAY GUN MAINTENANCE & CLEANING

To clean air cap and fluid tip, brush exterior with a stiff bristle brush. If necessary to clean cap holes, use a broom straw or toothpick if possible. If a wire or hard instrument is used, extreme care must be taken to prevent scratching or burring of the holes which will cause a distorted spray pattern.

To clean fluid passages, remove excess material, then flush with gun wash solution. Wipe the gun exterior with a dampened cloth. Never completely immerse in any solvent or cleaning solutions as this is detrimental to the lubricants and life of the spray gun.

SPRAY GUN DISASSEMBLY / ASSEMBLY

KEY	
	Order for disassembly <i>(reverse for assembly)</i>

DISASSEMBLY TIP & NEEDLE

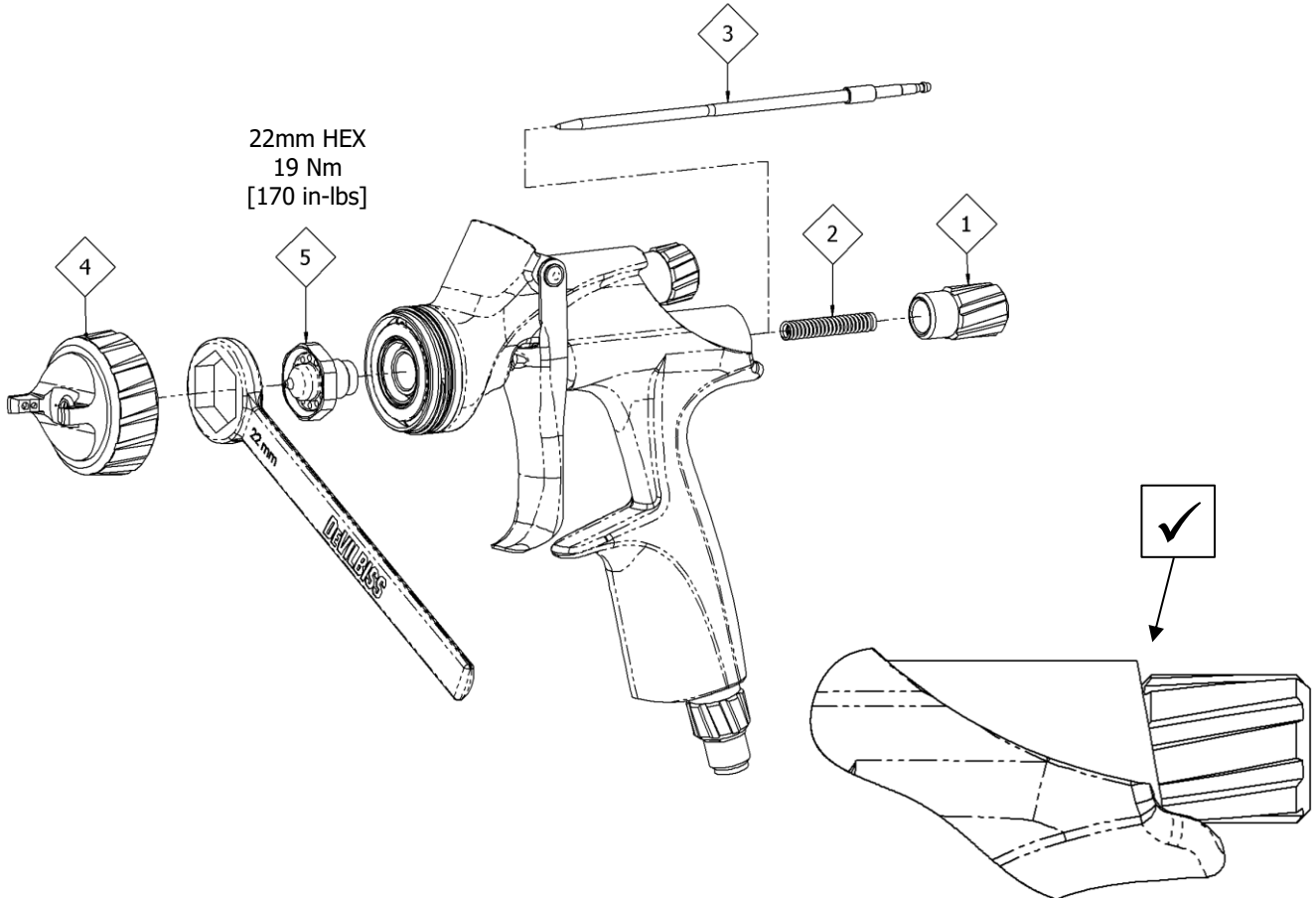

NOTE

When replacing the fluid tip or fluid needle, replace tip, needle and fluid packing at the same time. Using worn parts can cause fluid leakage. Do not overtighten.

NOTE

When removing air cap from retaining ring, do not remove slip ring or retaining ring seal from retaining ring. Damage to the parts may occur.

The slip ring and retaining ring seal are not available as replacement parts.

Simply wipe parts clean and reassemble with new or clean air cap.

DISASSEMBLY PACKING

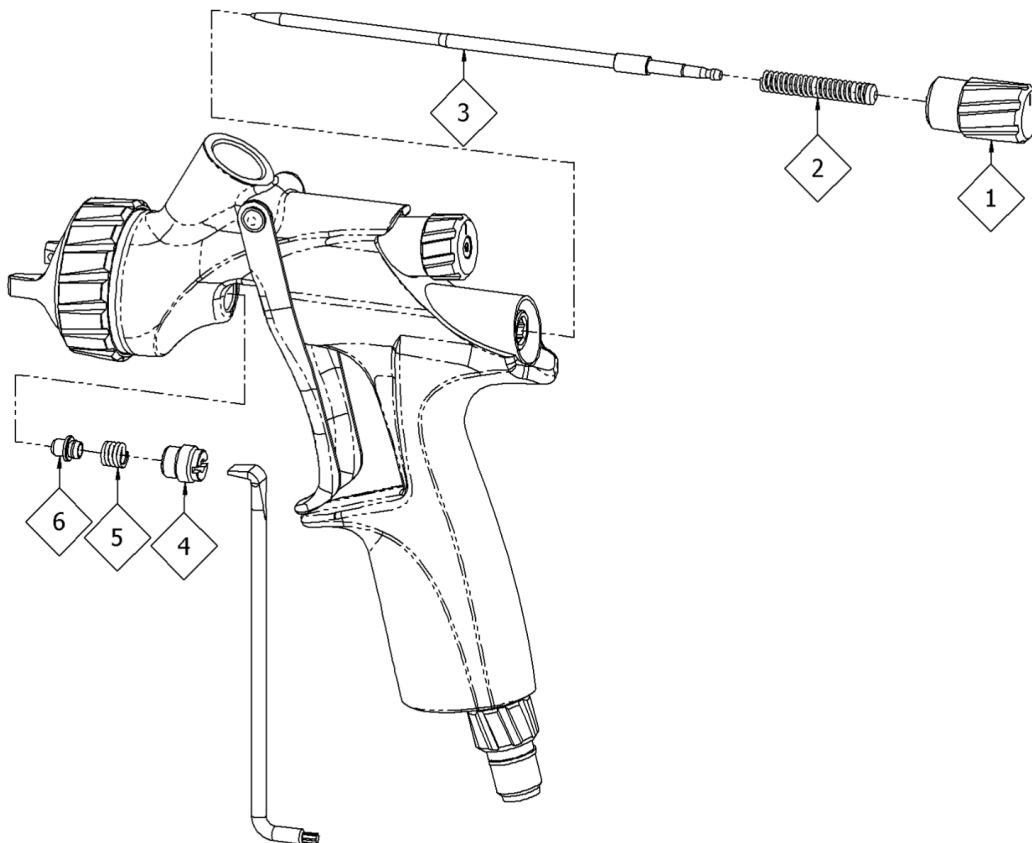

DISASSEMBLY TRIGGER

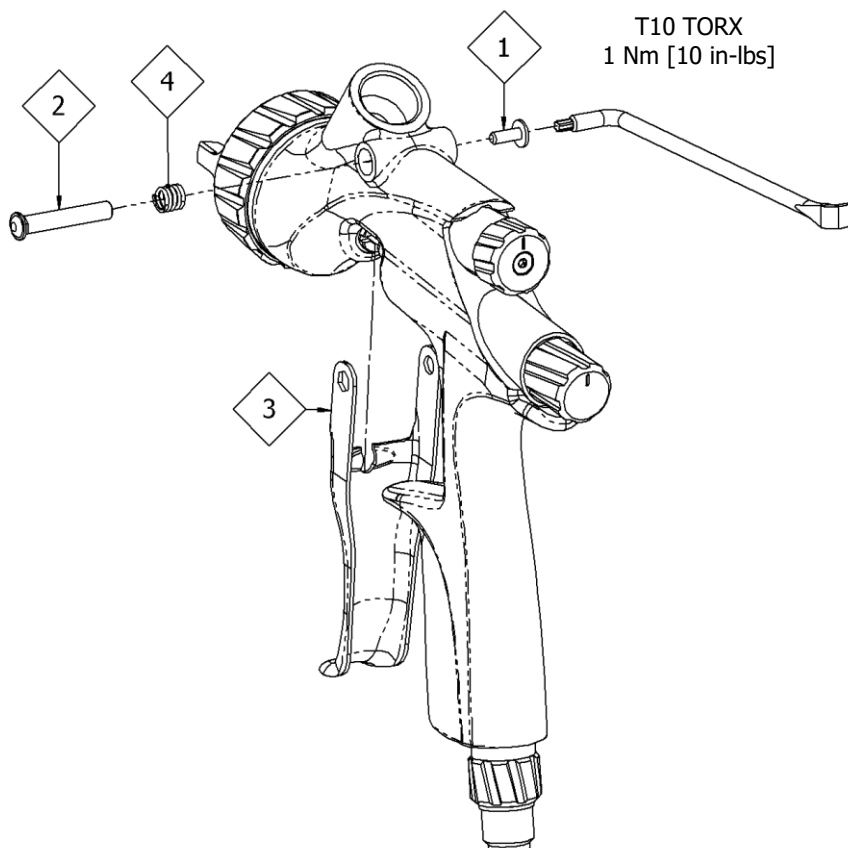

DISASSEMBLY SPRAYHEAD

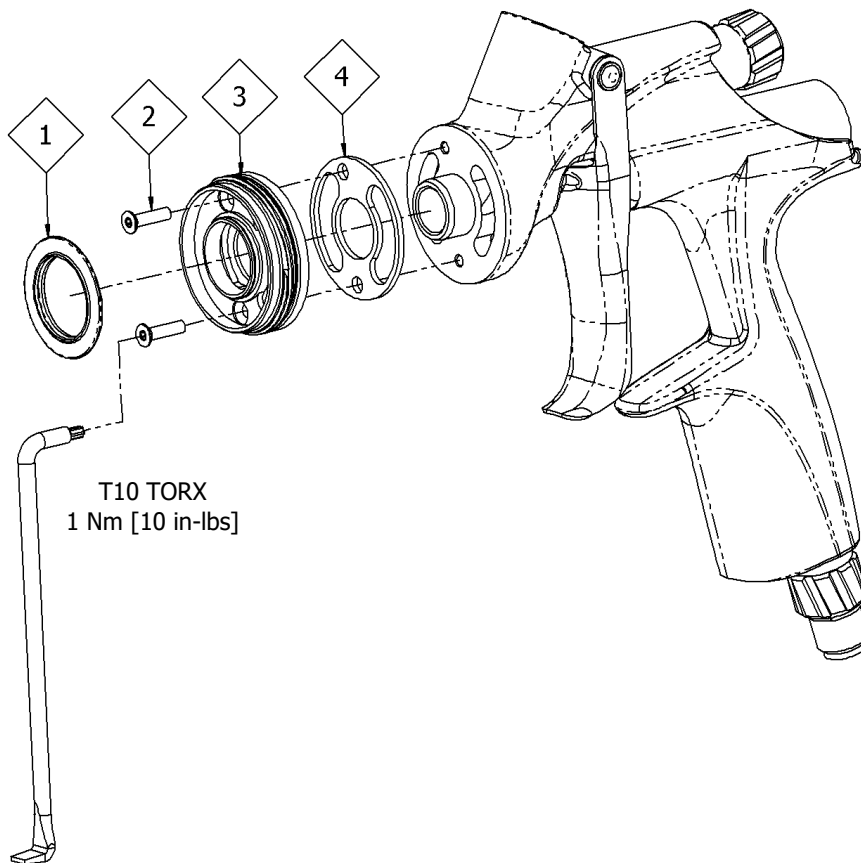

DISASSEMBLY FLOW VALVE

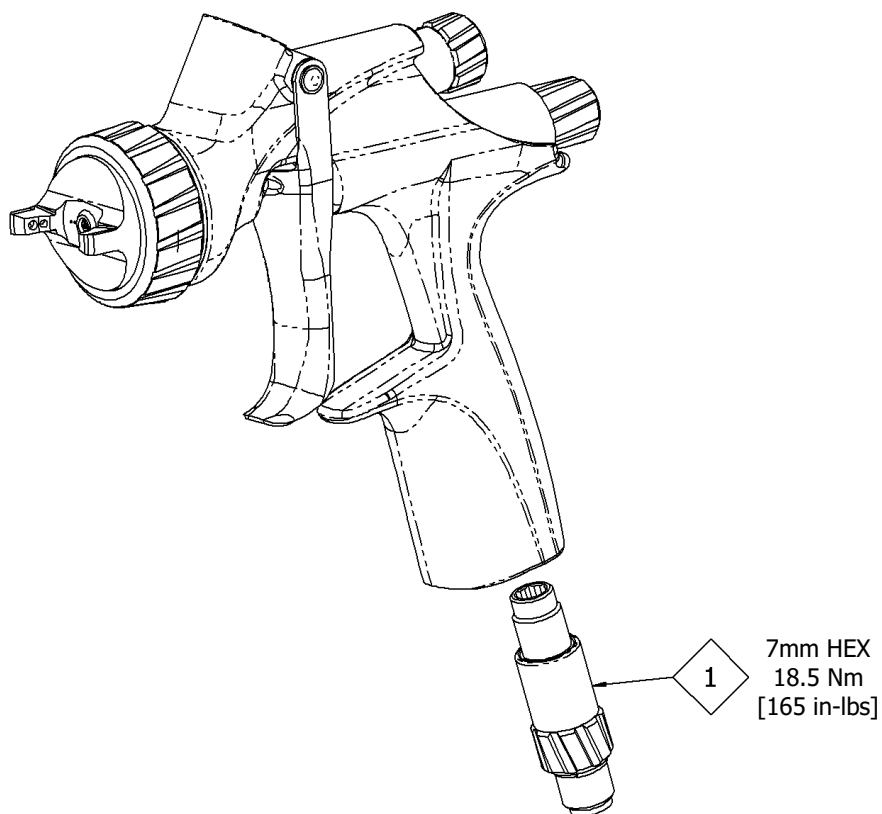

DISASSEMBLY AIR VALVE

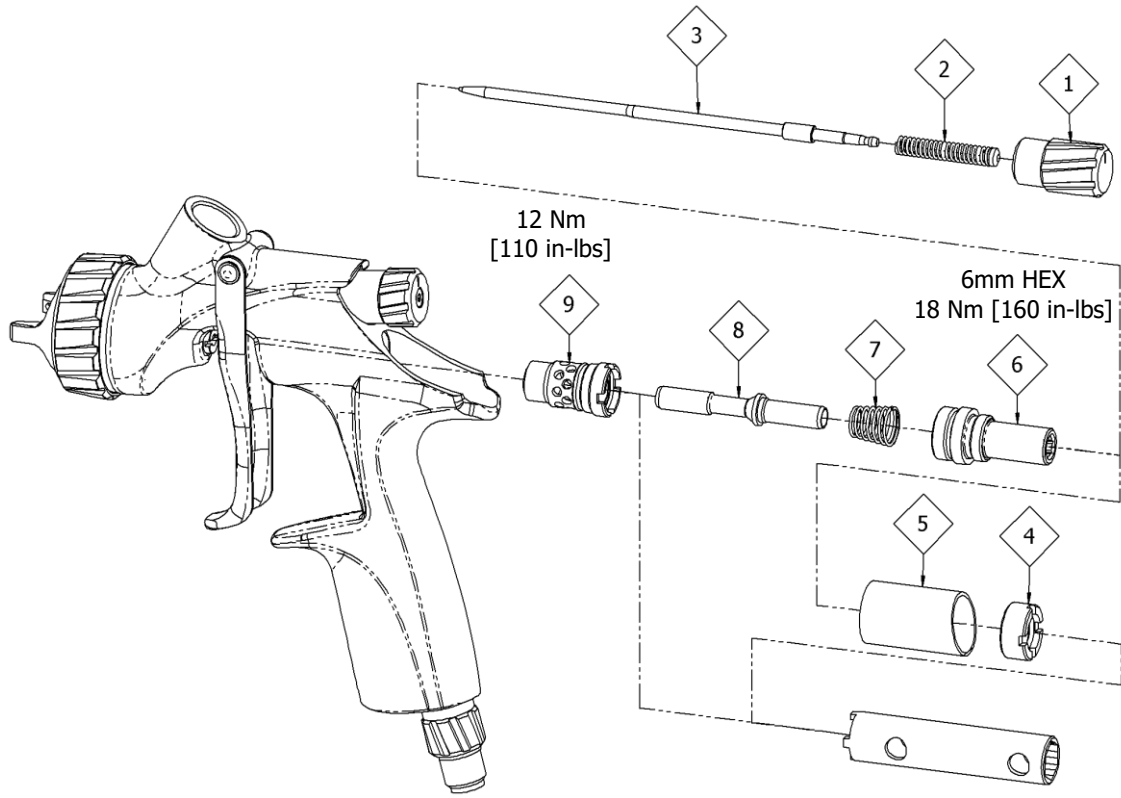

TO CHANGE IDENTIFICATION SLEEVE ONLY

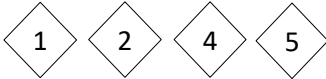

SPREADER VALVE REPLACEMENT

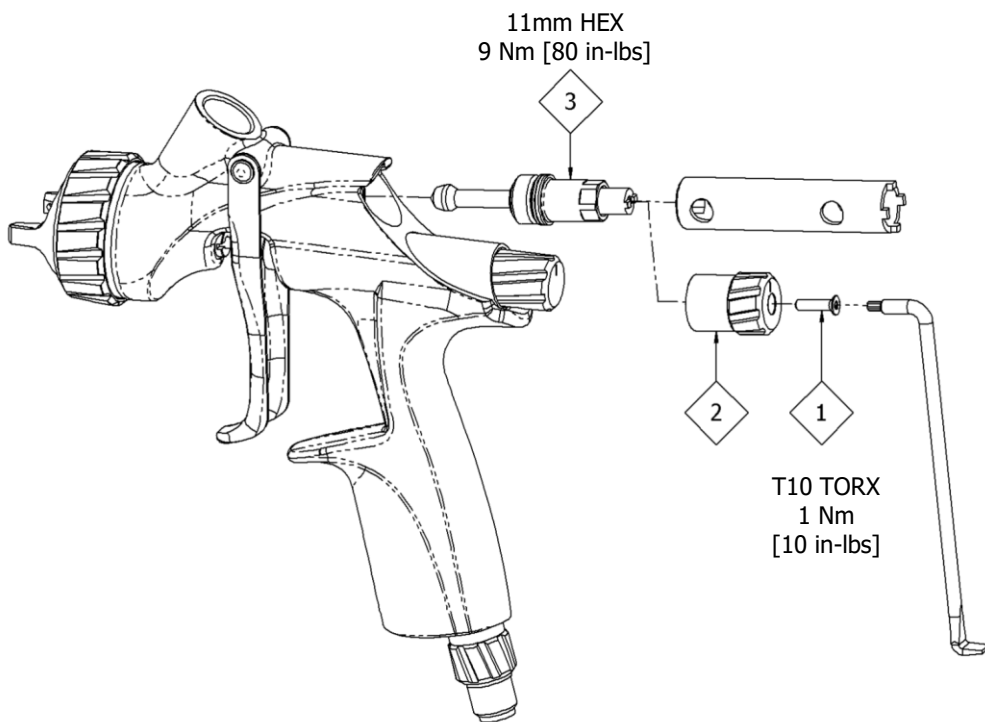

TROUBLESHOOTING MECHANICAL PERFORMANCE

GENERAL FAULTS	CAUSE	CORRECTION
Will not spray.	No air pressure at gun.	Check air supply and air line.
	Fluid needle adjustment knob not open enough.	Open fluid needle adjustment knob.
Gun spits paint when triggering on and off.	Incorrect needle fitted to gun.	Check fluid tip/needle selection chart and fit correct item.
	Excessive needle wear.	Replace with new needle.
	Excessive fluid tip wear.	Replace with new fluid tip.
Gun spits paint when triggering on due to paint build-up inside air cap between spraying operations.	Fluid tip not fitted correctly in gun head.	Tighten.
	Fluid tip/needle leakage.	Check for damage or blockage.
Paint build-up on fluid tip.	Fluid tip not fitted correctly in gun head.	Tighten.
	Fluid tip/needle leakage.	Check for damage or blockage.
Paint build-up on air cap.	Damaged air cap holes.	Replace with new air cap.
	Gradual build-up of bounce-back on gun head.	Thoroughly clean.
Unable to get round spray	Fluid tip or sprayhead incorrectly fitted.	Remove, check components for damage and refit correctly.

When removing air cap from retaining ring, do not remove the ring seat from the retaining ring. Damage to the parts may occur. Simply wipe parts clean and reassemble with new or clean air cap.

FLUID FAULTS	CAUSE	CORRECTION
Slow fluid leak from fluid tip and needle seat.	Fluid tip internal seat scored damaged or worn.	Replace.
	Fluid needle external profile damaged or worn.	Replace.
	Contamination on needle or tip mating surfaces preventing good seal.	Thoroughly clean.
	Incorrect fluid tip for fluid needle fitted to gun.	Check tip/needle selection chart and fit correct item.
	Sluggish needle.	Lubricate packing.
	Tight packing nut.	Adjust.
Major fluid leak or fluid jetting from fluid tip and needle seat.	Contamination on needle or tip mating surfaces preventing good seal.	Remove tip and needle and thoroughly clean.
	Incorrect fluid tip for fluid needle fitted to gun.	Check tip/needle selection chart and fit correct item.
Slow fluid leak from needle packing.	Fluid needle packing worn or loose.	Tighten or replace as necessary.

AIR FAULTS	CAUSE	CORRECTION
Small air leak from air cap when gun is not triggered.	Air Valve Stem contaminated and not correctly seating.	Remove Air Valve Stem and thoroughly clean valve shaft and seating surfaces.
	Air Valve Stem seal damaged or missing.	Replace.

TROUBLESHOOTING SPRAY PERFORMANCE

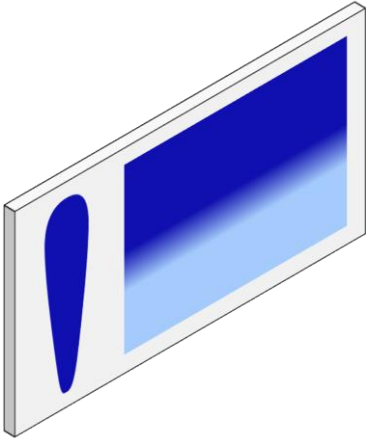
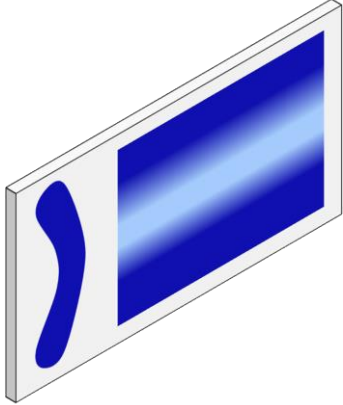
CONDITION	CAUSE	CORRECTION
<p>Heavy top or bottom pattern.</p> 	<p>Material build-up on air cap, plugged horn holes, centre holes or jets.</p>	<p>Soak cap or tip in suitable solvent and thoroughly clean.</p>
	<p>Material build-up on fluid tip exterior or partially plugged fluid tip.</p>	<p>Replace fluid tip or air cap if necessary.</p>
	<p>Fluid tip or cap dirty or damaged.</p>	<p>Replace fluid tip or air cap if necessary.</p>
<p>Heavy right or left side pattern.</p> 	<p>Left or right side horn holes plugged.</p>	<p>Soak cap or tip in suitable solvent and thoroughly clean.</p>
	<p>Dirt or damage on left or right side of fluid tip exterior.</p>	<p>Replace fluid tip or air cap if necessary.</p>
<p>Remedies for the top-heavy, bottom-heavy, right-heavy and left-heavy patterns.</p>		
<p>Determine if the obstruction is on the air cap or the fluid tip. Do this by making a test spray pattern. Then, rotate the cap one-half turn and spray another pattern. If the defect is inverted, obstruction is on the air cap. Clean the air cap as previously instructed. Also check for dried paint just inside the cap centre hole opening, remove by washing with solvent.</p>		
<p>If the defect is not inverted, it is on the fluid tip. Clean tip. If problem persists, renew tip.</p>		

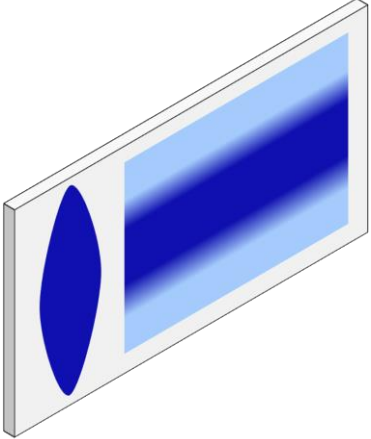
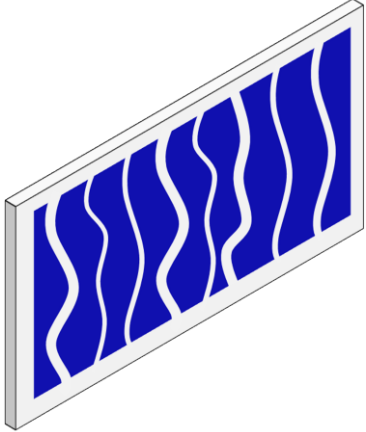
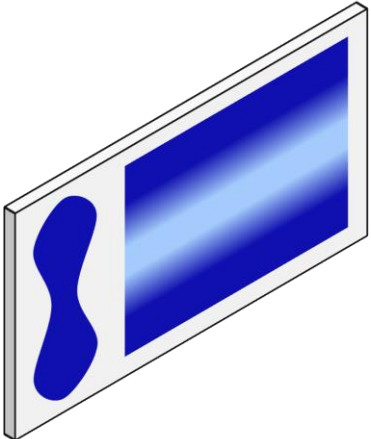
<p>Heavy centre pattern.</p> 	<p>Pattern adjustment valve set too low.</p>	<p>Turn out counter clockwise to achieve correct pattern.</p>
<p>Intermittent or 'fluttering' spray fan.</p> 	<p>Loose fluid tip.</p>	<p>Tighten.</p>
	<p>Fluid tip not seated correctly in gun head.</p>	<p>Remove fluid tip, clean components, check cone seating on tip and gun for damage or contamination.</p>
	<p>Partially obstructed fluid passage or hose.</p>	<p>Clean or replace.</p>
<p>Split spray pattern</p> 	<p>Not enough material flow.</p>	<p>Increase fluid flow by changing fluid tip size, opening needle control knob or increase fluid pressure on pressure feed container.</p>
	<p>Too high horn pressure.</p>	<p>Reduce air pressure by rotating pattern control valve clockwise.</p>
	<p>Too much air for fluid quantity used.</p>	<p>Reduce input air pressure.</p>

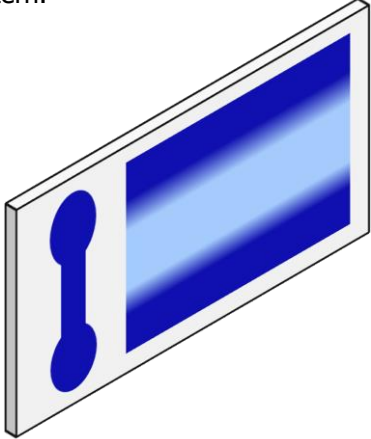
<p>Ball end heavy pattern.</p> 	<p>Too much fluid flow.</p>	<p>Change fluid tip for smaller size or change air cap for different specification air cap.</p>
<p>Excessive bounce-back.</p>	<p>Too much atomisation air pressure.</p>	<p>Reduce air pressure.</p>
	<p>Gun too far from surface.</p>	<p>Check distance (normally 150-200mm [6-8"]).</p>
<p>Runs and sags.</p>	<p>Too much fluid flow.</p>	<p>Adjust gun or reduce fluid pressure.</p>
	<p>Material too thin.</p>	<p>Mix properly or apply light coats/reduce fluid flow.</p>
	<p>Gun tilted at an angle.</p>	<p>Mount gun at right angle to work.</p>
<p>Thin, sandy coarse finish drying before it flows out.</p>	<p>Gun too far from surface.</p>	<p>Check distance.</p>
	<p>Too much air pressure.</p>	<p>Reduce air pressure and check spray pattern.</p>
	<p>Fluid flow too low.</p>	<p>Increase fluid flow by changing fluid tip size, supply pressure or turning needle control knob counter clockwise.</p>

DIMENSIONS

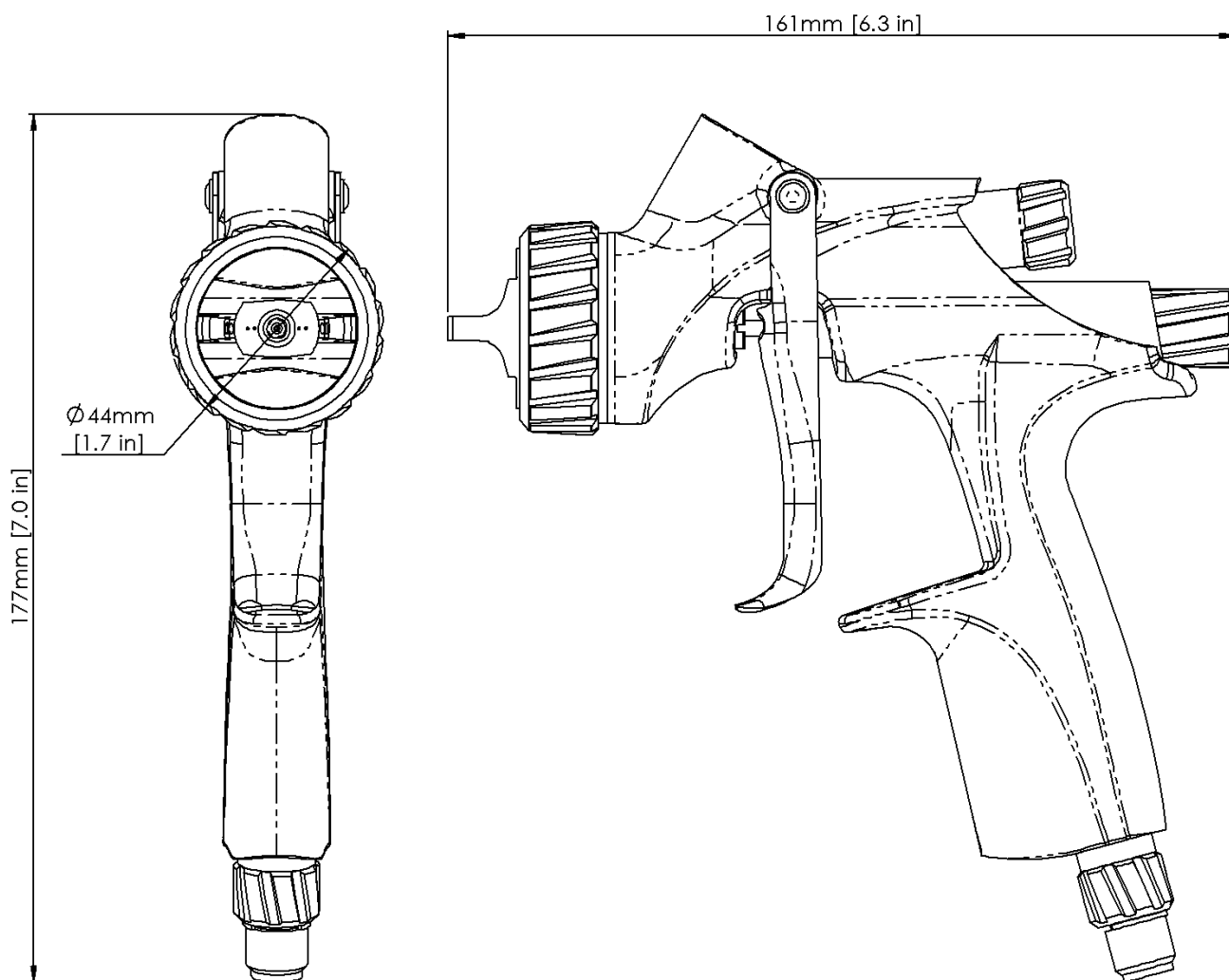

NOTES

NOTES

WARRANTY POLICY

This product is covered by Carlisle Fluid Technologies' materials and workmanship limited warranty. The use of any parts or accessories, from a source other than Carlisle Fluid Technologies, will void all warranties. Failure to reasonably follow any maintenance guidance provided, may invalidate any warranty.

For specific warranty information please contact Carlisle Fluid Technologies.

Carlisle Fluid Technologies is a global leader in innovative finishing technologies. Carlisle Fluid Technologies reserves the right to modify equipment specifications without prior notice.

DeVilbiss®, Ransburg®, MS®, BGK®, and Binks® are registered trademarks of Carlisle Fluid Technologies, Inc.

© 2019 Carlisle Fluid Technologies, Inc.

All rights reserved.

For technical assistance or to locate an authorised distributor, contact one of our international sales and customer support locations below.

Region	Industrial / Automotive	Automotive Refinishing
Americas	Tel: 1-888-992-4657 Fax: 1-888-246-5732	Tel: 1-800-445-3988 Fax: 1-800-445-6643
Europe, Africa, Middle East, India	Tel: +44 (0)1202 571 111 Fax: +44 (0)1202 573 488	
China	Tel: +8621-3373 0108 Fax: +8621-3373 0308	
Japan	Tel: +81 45 785 6421 Fax: +81 45 785 6517	
Australia	Tel: +61 (0) 2 8525 7555 Fax: +61 (0) 2 8525 7575	

For the latest information about our products, visit www.carlisleleft.com



SOLUTIONS FOR YOUR WORLD